

FILTRO ICE



FEATURES

- ✓ Laminated filter manufactured with polyester resin and fiber glass.
- ✓ Excellent exterior finish in gelcoat.
- ✓ Filter color: RAL 5024
- ✓ ¼" air and water drain
- ✓ Connections to six positions multiport valve with: filtration, backwash, rinse, recirculate, waste and closed operations.
- ✓ Black top lid with screws.
- ✓ Maximum temperature: 50°C
- ✓ Maximum pressure: 2.5 bar.

CARACTERÍSTICAS

- ✓ Filtros laminados con resina de polyester y fibra de vidrio.
- ✓ Excelente acabado exterior en gelcoat.
- ✓ Filtro color: RAL 5024
- ✓ Purga de agua y aire ¼"
- ✓ Conexiones para válvula selectora de seis vías con operaciones de: filtración, lavado, enjuague, recirculación, vaciado y cerrado.
- ✓ Tapa superior con tornillos negra.
- ✓ Máxima temperatura: 50°C.
- ✓ Máxima presión: 2.5 bar.

FILTER DETAILS



- Cone diffuser
- Cono difusor



- Fitted with 1" laterals
- Equipado con brazos colectores 1"



- Black top lid with screws
- Tapa superior negra con tornillos

TECHNICAL DATA

PACKAGING

Code	Model (mm)	Connections (mm/inch)		Filtering velocity (m³/h/m²)	Filtration Area (m²)	Flow (m³/h)	Maximum pressure (bar)	Sand (0.4-0.8mm) (kg)	Net weight (kg)	D (mm)	H (mm)	M (mm)	N (mm)	Units per pallet	Box dimension (cm)
		mm	inch												
73177-0100	350	50	1 ½"	50	0.096	5	2.5	50	15	390	755	393	268	15	39x39x76
73178-0100	450	50	1 ½"	50	0.16	8	2.5	70	15	520	760	434	309	10	52x52x76
73179-0100	500	50	1 ½"	50	0.19	10	2.5	95	17	520	855	417	292	8	56x56x85
73180-0100	600	50	1 ½"	50	0.30	14	2.5	125	21	560	850	442	317	8	65x65x86
73181-0100	650	50	1 ½"	50	0.33	17	2.5	200	22	700	890	479	354	8	70x70x89
73182-0100	750	63	2"	50	0.44	22	2.5	290	30	800	930	555	325	2	80x80x93
73183-0100	900	63	2"	50	0.64	32	2.5	500	48	960	1100	659	389	2	96x96x110

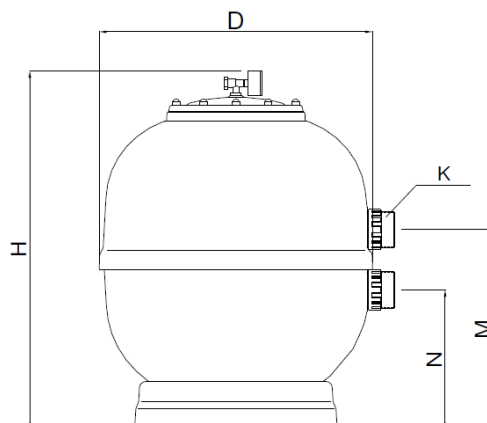

TESTED
ACCORDING TO
EN16713-1

PROBADO DE
ACUERDO A
EN16713-1